



TRUE MANUFACTURING CO., INC.
U.S.A. FOODSERVICE DIVISION

2001 East Terra Lane • O'Fallon, Missouri 63366-4434 • (636)240-2400
 Fax (636)272-2408 • Toll Free (800)325-6152 • Intl Fax# (001)636-272-7546
 Parts Dept. (800)424-TRUE • Parts Dept. Fax# (636)272-9471 • www.truemfg.com

Project Name: _____

Location: _____

Item #: _____ Qty: _____

Model #: _____

A/A #

S/S #

Model:
THAC-48-S-HC-LD

THAC Series:

Horizontal Air Curtain Refrigerated Merchandiser with Stainless Exterior, Hydrocarbon Refrigerant & LED Lighting



THAC-48-S-HC-LD

- ▶ True's air curtain merchandisers are designed with enduring quality that protects your long term investment.
- ▶ True's commitment to using the highest quality materials and oversized refrigeration systems provides the user with colder product temperatures and lower utility costs in a convenient spot merchandiser for packaged food and beverage.
- ▶ Uniquely sized for placement in a variety of popular impulse merchandising locations.
- ▶ Factory engineered, self-contained refrigeration system using environmentally friendly R290 hydrocarbon refrigerant that has zero (0) ozone depletion potential (ODP), & 0.02 global warming potential (GWP).
- ▶ Energy efficient, factory balanced, refrigeration system holds 35°F to 40°F (1.6°C to 4.4°C).
- ▶ True's exclusive self-cleaning RCU Technology eliminates the need to clean the condenser coil, reduces energy consumption and helps maintain the coldest temperatures and freshest product.
- ▶ Exterior - gleaming stainless steel for those who appreciate the value of stainless.
- ▶ Interior - matching attractive, clear aluminum interior liner with stainless steel floor.
- ▶ LED interior lighting, safety shielded.
- ▶ Air curtain top provides fast, easy access to product while maximizing attention to merchandising.
- ▶ Entire cabinet structure is foamed-in-place using a high density, polyurethane insulation that has zero ozone depletion potential (ODP) and zero global warming potential (GWP).

ROUGH-IN DATA

Specifications subject to change without notice.
 Chart dimensions rounded up to the nearest 1/8" (millimeters rounded up to next whole number).

Model	Shelves	Cabinet Dimensions (inches) (mm)			HP	Voltage	Amps	NEMA Config.	Cord Length (total ft.) (total m)	Crated Weight (lbs.) (kg)
		W	D	H						
THAC-48-S-HC-LD	3	48 1/8 1223	30 1/8 766	43 3/8 1102	1/3 N/A	115/60/1	5.3 N/A	5-15P	10 3.05	395 180



APPROVALS:

AVAILABLE AT:

Model:
THAC-48-S-HC-LD

THAC Series:

Horizontal Air Curtain Refrigerated Merchandiser with
Stainless Exterior, Hydrocarbon Refrigerant & LED Lighting



STANDARD FEATURES

DESIGN

- Designed using the highest quality materials and components to provide the user with colder product temperatures and lower utility costs in an attractive merchandiser that brilliantly displays package food and beverage.

REFRIGERATION SYSTEM

- Factory engineered, self-contained refrigeration system using environmentally friendly R290 hydrocarbon refrigerant that has zero (0) ozone depletion potential (ODP), & 0.02 global warming potential (GWP).
- Time initiated, time terminated off cycle defrost system
- Extra large evaporator coil balanced with higher horsepower compressor and large condenser; maintains cabinet temperatures of 35°F to 40°F (1.6°C to 4.4°C).
- Sealed, self-lubricated evaporator fan motor and larger fan blades give True merchandisers a more efficient, low velocity, high volume airflow design, colder holding temperatures and faster recovery in high use situations.
- Condensing unit accessed from front of cabinet, slides out for easy maintenance.

- True's exclusive self-cleaning RCU Technology eliminates the need to clean the condenser coil, reduces energy consumption and helps maintain the coldest temperatures and freshest product.

CABINET CONSTRUCTION

- Exterior - gleaming stainless steel for those who appreciate the value of stainless.
- Interior - attractive, clear aluminum liner with stainless steel floor.
- Cabinet fitted with leg levelers.
- Insulation - entire cabinet structure is foamed-in-place using a high density, polyurethane insulation that has zero ozone depletion potential (ODP) and zero global warming potential (GWP).

SHELVING

- Three (3) level tiered stainless steel floor.

LIGHTING

- LED interior lighting, safety shielded.

MODEL FEATURES

- Listed under NSF/ANSI Standard 7 for the storage and/or display of packaged and bottled product.

ELECTRICAL

- Unit completely pre-wired at factory and ready for final connection to a 115/60/1 phase - 15 amp dedicated outlet. Cord and plug set included.



115/60/1
NEMA-5-15R

RECOMMENDED OPERATION CONDITIONS

- Designed to operate in an environment where temperatures and humidity do not exceed 75°F (24°C) and 55% relative humidity
- Unit should not be installed near HVAC vents, fans on doorways that will disrupt the air curtain and compromise the function of the cabinet. Unit should not be installed in direct sunlight.
- Model will run most efficiently when completely loaded with product.
- Drain plumbing hookup recommended.

OPTIONAL FEATURES/ACCESSORIES

Upcharge and lead times may apply.

- 2" (51 mm) diameter castors
- Bumper guards.
- Night cover.

PLAN VIEW

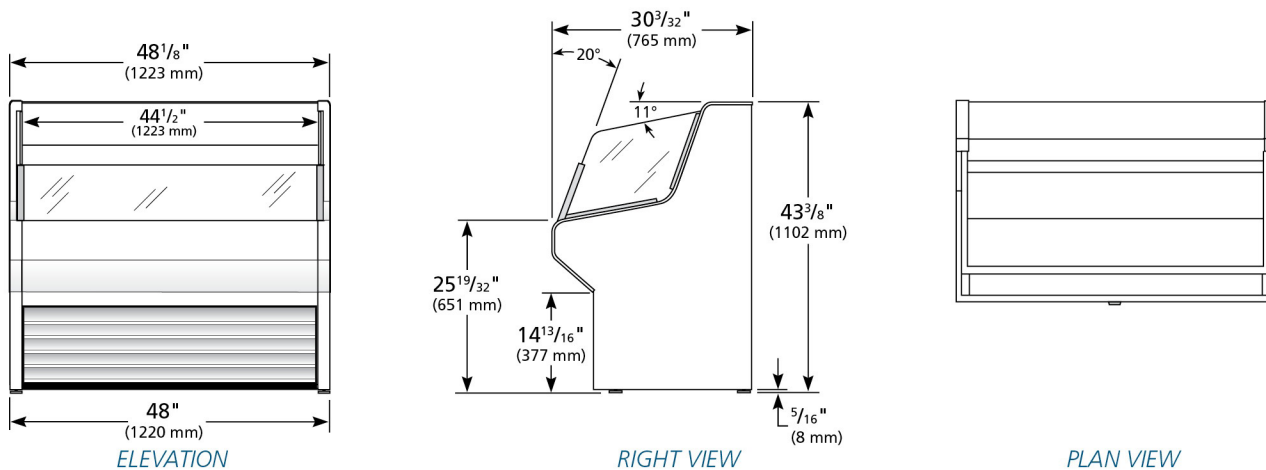

METRIC DIMENSIONS ROUNDED UP TO THE NEAREST WHOLE MILLIMETER

SPECIFICATIONS SUBJECT TO CHANGE WITHOUT NOTICE



Model	Elevation	Right	Plan	3D	Back
THAC-48-S-HC-LD					

TRUE MANUFACTURING CO., INC.

2001 East Terra Lane • O'Fallon, Missouri 63366-4434 • (636)240-2400 • Fax (636)272-2408 • Toll Free (800)325-6152 • Intl. Fax# (001)636-272-7546 • www.truefmfg.com